

A High-Performance Micro Light-Emitting Diode Pixel Circuit Based on LTPO TFTs using a Pseudo Digital Driving Method

Jae-Won Jung^{* **}, Joon-Sung Choi^{***}, Kook-Chul Moon^{****},

Soo-Hyung Kim^{**}, Yong-Sang Kim^{* ***, ****}

^{*} Dept. of Digital Media and Communications Engineering, Sungkyunkwan University, Suwon, Korea

^{**} Visual Display Business, Samsung Electronics Co. Ltd., Suwon, Korea

^{***} Department of Display Convergence Engineering, Sungkyunkwan University, Suwon, Korea

^{****} Department of Electrical and Computer Engineering, Sungkyunkwan University, Suwon, Korea

Abstract

In this paper, we proposed a novel pulse width modulation (PWM) pixel circuit for micro light-emitting diode (μ LED) modular displays with a pseudo digital driving method and external compensation system. The proposed circuit can simplify the compensation circuit by using the external compensation system and a stepwise signal with an inverter. The proposed pixel circuit exhibited stable operation with an error rate lower than 1% under threshold voltage of an inverter variations of $\pm 0.2V$. The transient time of simulated μ LED current was about below 30 ns. Furthermore, the proposed pixel circuit achieved stable 8-bit grayscale without internal compensation elements.

Author Keywords

MicroLED, LTPO, TFT, pixel circuit, PWM, inverter, external compensation system, stepwise signal, pseudo digital driving.

1. Introduction

Micro light-emitting-diode (μ LED) displays have garnered significant attention in recent years due to their superior characteristics over traditional display technologies such as active-matrix liquid-crystal display (AMLCD) and active-matrix organic light-emitting diode (AMOLED) displays. μ LEDs offer advantages including low power consumption, long lifespan, high contrast ratio, fast response time, and free from burn-in issue which is common in OLED displays. These features make μ LEDs an ideal candidate for next generation display technologies [1].

Samsung Electronics' Visual Display (VD) Business has led the development of μ LED displays. In 2018, the company launched *The Wall*, the world's first μ LED modular display, followed by the 89-inch Active-Matrix (AM) μ LED TV in 2023 [2], and a transparent μ LED at CES 2024. These groundbreaking products highlight Samsung's continuous investment and dedication to developing μ LED technology.

The pixel circuit is one of the crucial technologies for TFT-based μ LED displays. However, several challenges arise when scaling up to modular μ LED displays. The μ LED pixel circuits have been adopted pulse width modulation (PWM) because pulse amplitude modulation (PAM) could lead to image distortion by shifting the wavelength of μ LED. To control the emission period of μ LED maintaining a constant current, the previously reported pixel circuit used analog control signals, which delayed the transient time and caused image distortion at low grayscale levels. To solve this problem, Recent studies have introduced the use of a stepwise signal, called STEP [3]. This pseudo digital driving switches driving TFT so quickly and maintains low luminance error rate without additional compensation. To implement these features, a high-performance data driver integrated circuit (IC) is re-

quired. Given that the company has extensive experience in developing μ LED displays using ICs, the company has a strong advantage in this area.

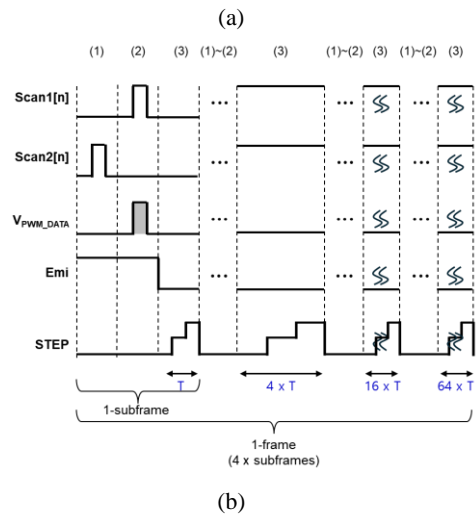
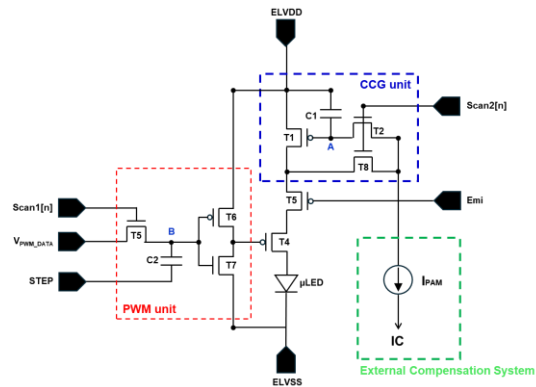

Figure 1. (a) Circuit schematic and (b) Timing diagram

In this study, we proposed a μ LED pixel circuit based on low-temperature polycrystalline silicon and metal-oxide (LTPO) TFTs using pseudo digital driving method without V_{TH} compensation internally. The combination of a stepwise control signal and an inverter could fix the gate voltage of driving TFT to either high or low, like digital driving. Furthermore, the proposed pixel circuit adopted the external compensation system to generate a constant current of μ LED regardless of threshold voltage (V_{TH}) variation of driving TFT. As a result, the proposed pixel circuit was designed to be compact with stable operation. The transient time of the simulated μ LED current waveform is in the range of tens of

nanosecond and the simulated luminance error rate was below 1% under $\pm 0.2V$ the threshold voltage of inverter ($V_{TH,Inverter}$) variations. Furthermore, the proposed pixel circuit successfully expressed 8-bit grayscales.

2. Proposed Pixel Circuit

Figure 1. shows the circuit schematic and timing diagram of the proposed μ LED pixel circuit. The proposed μ LED pixel circuit consists of eight TFTs and two capacitors (8T2C): four p-type low-temperature polycrystalline silicon (LTPS) TFTs and four n-type metal-oxide TFTs. The proposed circuit is divided into the PWM unit, the constant current generation (CCG) unit, and the external compensation system, as shown in Figure 1(a). The PWM unit regulates the μ LED emission time divided into four subframe using the V_{PWM_DATA} with an LTPO inverter (T6, T7) and the STEP signal. The CCG unit generates a constant current of μ LED. Because T1 and T8 form a diode connection, The external compensation system compensates a V_{TH} of driving TFT of PWM unit (T1) by flowing current through external compensation system. The proposed μ LED pixel circuit operates in three periods: (1) the V_{TH} of T1 compensation period, (2) the Data input period, (3) the emission period.

In the V_{TH} of T1 compensation period, the Scan2[n] signal becomes high-level voltage. Then, T2 and T8 are turned on, the current starts to flow from ELVDD to the external compensation system through T1 and T8. Because T1 and T8 form diode connection, C1 can store the gate voltage of T1 for generating a constant current of μ LED.

In the data input period, V_{PWM_DATA} is applied to the input of an inverter through T5 and stored in C2. At this time, V_{PWM_DATA} is determined based on gray level.

At the start of emission period, the Emi signal becomes low-level voltage, turning on T3. The input node of an inverter is changed by a STEP signal through the capacitive-coupling effect of C2. The STEP signal increases stepwise, causing the input of the inverter to increase accordingly. When the input voltage becomes sufficient to transition a low output voltage, T4 is turned on and the μ LED begins to emit light. At the end of the emission period, Emi signal returns to a high-level voltage, turning off T3 and stopping the μ LED emission. Those (1) to (3) periods are repeated four times within one frame, and the total emission period equals the sum of its four subframes.

3. Results and Discussion

The operation of the μ LED pixel circuit was investigated using circuit simulation (SmartSpice, Silvaco). The parameter values of the proposed circuit are listed in Table 1.

Table 1. The parameter values of the proposed circuit

Parameter values			
W/L of T1 – T5	5 μ m/5 μ m	ELVDD	10 V
W/L of T6, T7	3 μ m/5 μ m	ELVSS	0 V
W/L of T8	5 μ m/5 μ m	Scan1[n]/ Scan2[n]	-3 ~ 13 V
C1, C2	100 fF	V_{PWM_DATA}	0, 3, 6, 9 V
STEP	0, 3, 6 V	Emi	-3 ~ 13 V

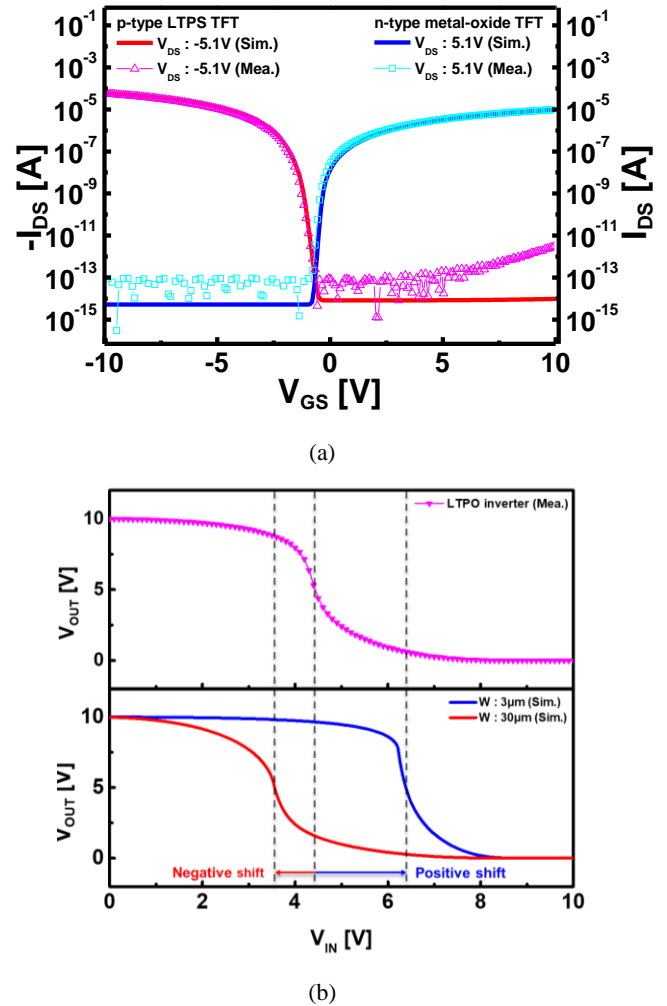

Figure 2. (a) Measured and simulated transfer characteristics of p-type LTPS and n-type metal-oxide TFTs and (b) measured and simulated VTC of an inverter.

Figure 2(a) plots the measured and simulated transfer characteristics of p-type LTPS and n-type metal-oxide TFTs. Figure 2(b) shows the measured and simulated voltage transfer curve (VTC) of the inverter, which illustrates the relationship between V_{IN} and V_{OUT} . We simulated the proposed μ LED pixel circuit using the TFTs exhibited in Figure 2(a). However, in case of an LTPO inverter, We intentionally shifted $V_{TH,Inverter}$ to bypass the transient region of inverter by changing the W/L ratio of the LTPO TFT. As a result, the proposed pixel circuit ensure the fixed V_{GS} of T4 either High or Low level. As shown in Figure 2(b), shifting $V_{TH,Inverter}$ in the positive direction has an advantage in reducing the TFT size, and thus this approach was chosen to optimize the design.

Figure 3. plots the μ LED current waveforms of fourth subframe period by changing the V_{PWM_DATA} . When V_{PWM_DATA} is 9V, the inverter output becomes low at the beginning of the subframe emission period, and the μ LED emits light throughout the entire subframe emission period. At 6V, the μ LED emits light for 2/3 of the period, while at 3V, it emits light for 1/3 of the period. At 0V, even if the STEP voltage reaches its maximum, it does not exceed the inverter threshold, so no light is emitted.

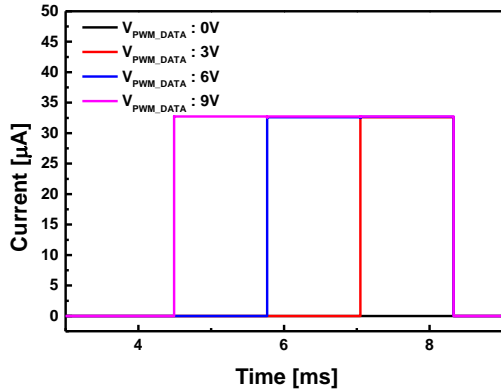

Figure 3. Simulated μ LED current waveforms of fourth sub-frame by changing the V_{PWM_DATA}

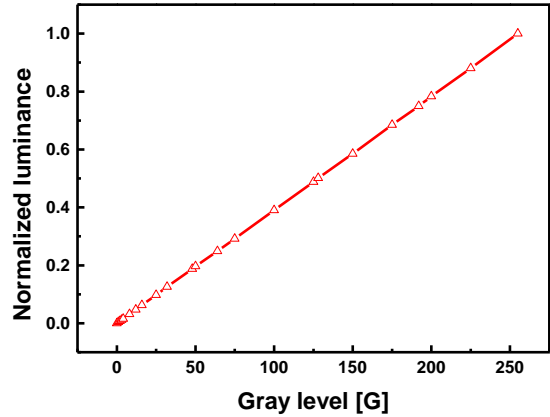

Figure 5. Normalized luminance with respect to gray levels.

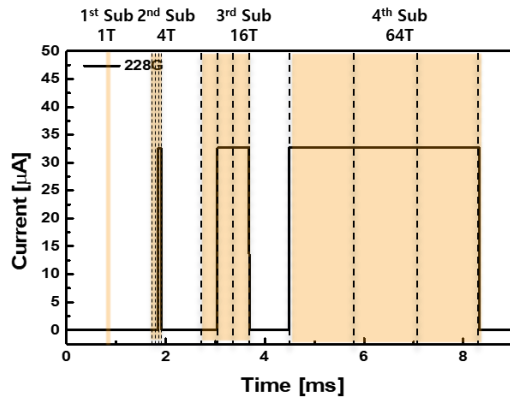

Figure 4. Simulated μ LED current waveforms at a gray level of 228G

Figure 4 illustrates the μ LED current waveform at a gray level of 228. Each subframe interval: 1T, 4T, 16T, and 64T is divided into three segments, allowing to express 8-bit grayscales. In the case of a gray level of 228, applying 0V, 3V, 6V, and 9V to the respective subframes successfully expresses the accurate 228 gray level.

Figure 5. shows the normalized luminance with respect to changing gray levels. As mentioned above, the emission time of a frame is the sum of the emission times of its four subframes. Therefore, μ LED current was integrated over its respective emission time to calculate the luminance. In conclusion, the proposed pixel circuit could express 8-bit grayscale clearly.

The conventional μ LED pixel circuit have introduced the use of inverter in PWM circuits to shorten the transient time of the emission period [4]. Despite these improvements, the existing approach has still face limitations in achieving extremely low gray levels due to the analog control signal. Additionally, the analog control method requires circuit for compensating V_{TH} of driving TFT. In contrast, The STEP signal itself can rapidly change the gate node of driving TFT, reducing the transient time to 2ms. However, the proposed μ LED pixel circuit reduced the transient time to below thirty nanoseconds by using STEP signal with inverter. Because the STEP signal can bypass the transient period of inverter, the output of inverter can switch high level and low level

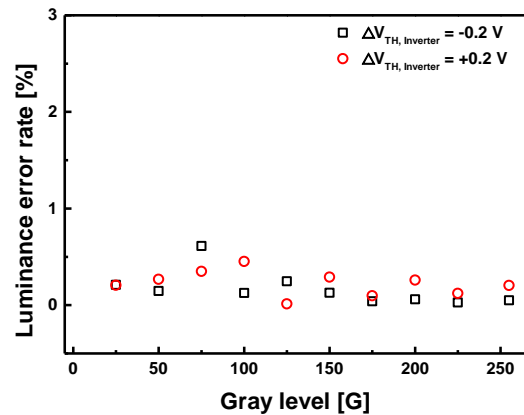

Figure 6. Simulated luminance error rate of the proposed μ LED pixel circuit for different $\Delta V_{TH, Inverter}$ condition.

directly like digital driving. The proposed μ LED pixel circuit could express low gray level more accurately with shortened transient time. Additionally, thanks to this fast transient time, the proposed pixel circuit could express 10-bit grayscale if a 256T sub-frame is added.

We investigated the operation of the proposed μ LED pixel circuit by varying the $V_{TH, Inverter}$. As mentioned above, Because the STEP signal transitions sharply between two levels, the output of inverter could avoid the region where $V_{TH, Inverter}$ varies. Therefore, T4 shows stable current driving without compensation. Figure 6. illustrates the luminance error rate across all gray levels under $\Delta V_{TH, Inverter}$ of $\pm 0.2V$, and it can be observed that all error rates are below 1%. Consequently, The proposed μ LED circuit ensures consistent operation with $\Delta V_{TH, Inverter}$ variations.

4. Conclusion

In this study, we proposed a LTPO TFT-based μ LED pixel circuit that uses a stepwise control signal with an inverter and external compensation system. The proposed pixel circuit utilized a stepwise signal with an inverter to reduce transient time to tens of nanosecond, ensuring the accuracy of extremely low gray level expression. Additionally, this pseudo digital driving method, combined with an external compensation system, simplified the pixel circuit by eliminating the additional elements and signals for

compensation. Although the proposed pixel circuit was simplified, it could express 8-bit grayscales accurately and the simulated error rate was below 1% under $\Delta V_{TH, Inverter}$ of $\pm 0.2V$.

Consequently, We expect that this compact pixel circuit could improve some of the challenges for developing μ LED display: (1) the yield loss of TFT backplane caused by complex pixel circuits and (2) the inaccurate low gray level expression due to delayed transient time.

In future work, rather than finishing on the simulation level, we are working on the layout of the proposed pixel circuit to fabricate test element group (TEG). If the performance evaluation of TEG proves feasibility, it could potentially be applied to next generation μ LED display products.

5. Acknowledgements

The EDA Tool was supported by the IC Design Education Center (IDEC), Korea

6. References

1. Huang, Y., Hsiang, E. L., Deng, M. Y., & Wu, S. T. (2020). Mini-LED, Micro-LED and OLED displays: present status and future perspectives. *Light: Science & Applications*, 9(1), 105. Available from: <https://www.nature.com/articles/s41377-020-0341-9>
2. Oh, J, Kim, J. H, Lee, J, Jung, E. K, Oh, D, Min, J, H, Im, Y.-S. Kim. (2021). Pixel circuit with P-type low-temperature polycrystalline silicon thin-film transistor for micro light-emitting diode displays using pulse width modulation. *IEEE Electron Device Letters*, 42(10), 1496-1499. Available from: <https://ieeexplore.ieee.org/abstract/document/9521237>
3. Im, H., Jung, E. K., & Kim, Y. S. (2023, June). P-23: Micro Light-Emitting Diode Pixel Circuit Based on IGZO TFTs using a Stepwise Control Signal. In *SID Symposium Digest of Technical Papers* (Vol. 54, No. 1, pp. 1495-1498). Available from: <https://sid.onlinelibrary.wiley.com/doi/abs/10.1002/sdtp.16873>
4. Y. Liu, S. Que, Z. Song, J. Fu, X. Zheng, C. Liao, X. Wang, L. Lu, and S. Zhang (2023, April). P-24: An accurate and stable PWM pixel circuit based on LTPO TFTs for AM-micro-LED display. In *SID Symposium Digest of Technical Papers* (Vol. 54, No. S1, pp. 242-245). Available from: <https://sid.onlinelibrary.wiley.com/doi/abs/10.1002/sdtp.16273>