

Double-Data PHM Drive System Based on MicroLED Display

Jiaqing Li*, Zhou Zhang*, Qiping He*, Zhe Li*, XiaLing Liu*, Changwen Ma*, Pan Xu*, Guowei Zha*, Jianfeng Yuan*

*TCL China Star Optoelectronics Technology Co., Ltd., Wuhan, China

Abstract

This paper introduces a Double Data PHM drive system, focusing on PHM dimming technology, system design and verification. The system is implemented on FPGA and applied to the Micro LED display based on LTPS glass substrate. Compared with PWM dimming technology and PAM dimming technology, the amplitude and width of LED driving pulse in PHM dimming technology can be adjusted, and the control of Micro LED display brightness is more flexible^[1]. At present, the feasibility of Double Data PHM drive system has been verified on TCL CSOT 6.79 inch Micro LED products.

Author Keywords

Micro LED; PHM Dimming technology; Drive system; FPGA

1. Introduction

As an emerging LED technology, Micro LED is smaller in size than traditional LED and can be reduced to the micron level^[2]. It has the advantages of high brightness, high contrast ratio, high transparency, excellent reliability and wide color gamut^{[3][4]}. At present, the main driving modes of Micro LED display include pulse width modulation (PWM) and pulse amplitude modulation (PAM)^{[5][6]}. In PWM, the voltage at both ends of the LED is constant, and its luminous brightness is determined by the luminous time. The low gray level or low frequency refresh rate of the display has a short luminous time, resulting in flicker or inaccurate gray level brightness, which may cause visual fatigue, headache and other problems^[7]. In PAM, the brightness of LED is controlled by the voltage difference between the two ends of LED. However, the consistency of LED current curve under low brightness is poor in this mode, and the brightness of different LED chips is deviate, which leads to the phenomenon of spot defect on the screen^[8]. Especially in applications with high brightness requirements, such as PHUD and AR-HUD, the brightness of the product is required to be above 80,000 nits. High gray scale needs enough luminous time to ensure high brightness and LED luminous effect. Low gray scale requires a certain current value to improve the uneven brightness of LED. Therefore, the Micro LED display needs to use PAM at high gray level, and PWM at low gray level.

This paper presents a Double Data PHM drive system. In this system, DP / HDMI is used to transmit video data, FPGA is used to receive video data and send it to Source IC after processing. Then, the Source IC outputs an analog voltage to the LED drive circuit. A single LED unit on the Micro LED display is controlled by both PWM data and PAM data, and the LED luminous brightness is determined by both. PWM data and PAM data can be arbitrarily combined to meet different display requirements. For example, under the condition of low brightness, the PAM data is fixed, and the brightness of LED is controlled by PWM data, which can solve the problem of uneven brightness of LED. Under the high brightness condition, the PWM data is fixed, and the brightness of the LED is controlled by the PAM data, which can provide smooth brightness control and avoid flicker sensation. Finally, we have verified through experiments and proved that the Double Data PHM drive system can solve the display problem and improve the display quality effectively in Micro LED display.

2. System Design

The Double Data PHM driving system is based on the design of Micro LED display screen, and adopts PHM dimming technology to adjust the driving pulse width and driving pulse amplitude of LED according to the luminescence characteristics of Micro LED.

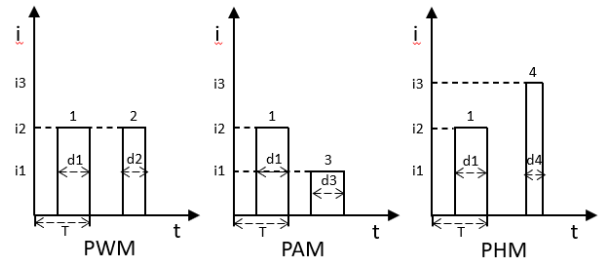

Figure 1. PWM, PAM, PHM dimming principle diagram

Figure 1 shows three different dimming techniques. Compared with the driving pulse 1, the amplitude of the driving pulse 2 remains unchanged, equal to i_1 , and the width is reduced from d_1 to d_2 , that is, PWM dimming technology. Compared with the driving pulse 1, the width of the driving pulse 3 remains unchanged, $d_1 = d_3$, and the amplitude is reduced from i_1 to i_2 , which is PAM dimming technology. Compared with the driving pulse 1, the width and amplitude of the driving pulse 4 have changed, but the average current is equal. In theory, the average brightness of the corresponding LED is also equal, which is PHM dimming technology. Therefore, PHM dimming technology can improve the uneven brightness of LED by adjusting the amplitude of the driving pulse while ensuring the average brightness of LED, and improve the flicker problem by adjusting the width of the driving pulse. Compared with PWM dimming technology and PAM dimming technology, PHM dimming technology is more flexible for LED drive pulse modulation.

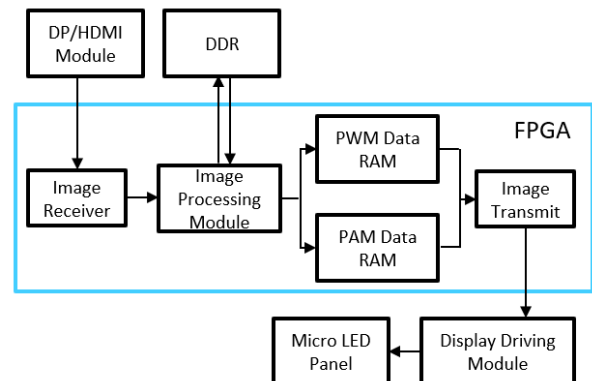

Figure 2. System structure diagram

The structure diagram of Double Data PHM driver system is shown in Figure 2, including data input module, processing module, storage module, display driver module and display module. The data input module is a DP / HDMI interface that provides pixel data

for video or pictures. The processing module uses FPGA as the main control chip to send, receive and process the image data, and controls the display driver module to output the gray-scale voltage to light the display module. The driver module includes Power IC, Level Shift IC, Source IC and Gamma IC, which provide power supply, drive signal and gray-scale voltage for the display module. The storage module is DDR and RAM, in which DDR is used to store image data and RAM is used to store the mapping data of image data, which can realize bit conversion and output PWM data and PAM data. The display module is a Micro LED display based on LTPS glass substrate.

The workflow of Double Data PHM drive system is as follows:

FPGA receives image data through DP / HDMI interface and stores it in DDR after internal logic processing. The FPGA includes the Demura algorithm, which can compensate the image data and improve the display quality of the Micro LED display. After receiving the data request of the driver module, the FPGA reads the pixel data from the DDR and outputs it to the PWM Data RAM and PAM Data RAM respectively to map the PWM data and PAM data. After receiving the mapping data, the display drive module outputs the corresponding PWM voltage and PAM voltage to the LED pixel drive circuit to light the Micro LED display screen.

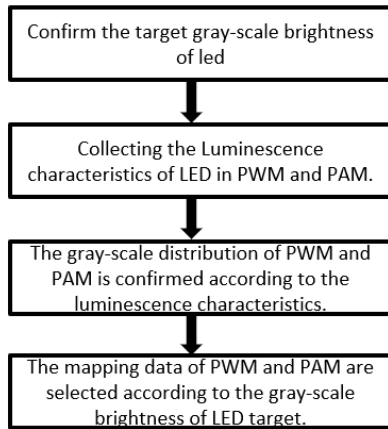

Figure 3. Flow chart of the data mapping

Figure 3 shows the data mapping process. This paper takes 24 bit image data (RGB : 3 * 8 bit) and 30 bit PWM data and PAM data (RGB : 3 * 10 bit) as examples. FPGA needs to map 8bit monochromatic pixel data to 10bit monochromatic PWM data and PAM data. Based on the needs of Micro LED brightness and color points, 256 PWM data and PAM data are selected from 1024 data.

Firstly, according to the target gray-scale brightness of the product, the maximum Gamma binding point voltage and the minimum Gamma binding point voltage are confirmed. For example, at 255 gray scale, the pulse amplitude and pulse width of the LED are the largest, which is the maximum luminous brightness, corresponding to the maximum Gamma binding point voltage. 0 gray scale, the pulse amplitude and pulse width of LED are the smallest, which is the minimum luminous brightness, corresponding to the minimum Gamma binding point voltage.

Then the PAM data is fixed, that is, the LED driver pulse amplitude is constant. The PWM data change from 0 to 1023 in turn, change the LED drive pulse width, record the LED luminous data of each condition, and obtain the luminous characteristics of the LED in the PWM mode. For example, as shown in Figure 4, is the relationship between Flicker and PWM data size. When the PWM data is 128,

Flicker = -50dB, which is at the critical value of visible flicker.

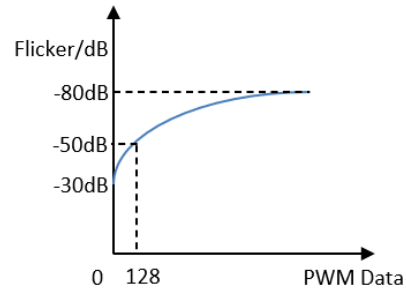

Figure 4. The relationship between Flicker and PWM Data

Then the PWM data is fixed, that is, the LED drive pulse width is unchanged. The data of PAM changes from 0 to 1023, and the amplitude of LED driving pulse changes. The LED luminous data of each condition is recorded, and the luminous characteristics of LED in PAM mode are obtained. For example, as shown in Figure 5, the number of LEDs for abnormal display is related to the size of PAM data. When the PAM data is greater than 512, the number of abnormal LEDs is 0.

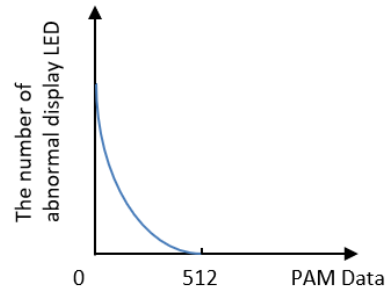

Figure 5. The relationship between the number of abnormal display LED and PAM Data

According to the LED luminous characteristics of PWM mode and PAM mode, the working gray scale of PWM mode and PAM mode is determined. For example, we hope that the number of LEDs with low gray-scale abnormal display is 0, that is, according to the target gray-scale brightness calculated in step 1 when the PAM data is 512, the boundary gray-scale is determined to be 128, that is, 0-127 gray-scale is set to PWM mode, and 128-255 gray-scale is set to PAM mode. The gray-scale distribution of PWM and PAM is shown in Table 1.

MODE	Gray Scale	PWM Data	PAM Data
PWM	0	0	1023
	63	511	767
	127	1023	511
PAM	128	1023	511
	191	1023	511
	255	1023	511

Finally, according to the gray-scale distribution scheme of PWM mode and PAM mode determined by step 4, the LED brightness data of the above data are traversed. In the high gray PAM stage, the PWM is fixed at 1023, and the PAM data is increased from 0 to

511 in turn. In the low gray PWM stage, the PAM data is fixed at 511, and the PWM data is increased from 0 to 511 in turn. The brightness data corresponding to each set of data is recorded. According to the gray-scale brightness of the LED target obtained in step 1, 256 10-bit data of the same brightness are selected from the 1024 brightness data, which are the PWM data and PAM data mapped by the image data.

3. System Verification

In order to verify the effectiveness of the Double Data PHM drive system, we conducted experiments on TCL CSOT 6.79-inch Micro LED products, and used a hybrid drive scheme of low-gray-scale PWM mode and high-gray-scale PAM mode to improve the uneven brightness and flicker of low-gray-scale LED. In the experiment, we determined the gray-scale distribution of PWM and PAM and the mapping data according to the data mapping method. The variation of spot defects and flicker with gray scale in PWM, PAM and PHM modes was recorded. Table 2 shows the TCL CSOT 6.79 inch Micro LED product parameters.

Size	6.79-inch	Luminance	45000nit
PPI	127	Resolution	566RGB*650
Pitch	0.2mm	Frame rate	120Hz
Application	PHUD		

According to the recorded experimental data, we draw the following conclusions:

Compared with PAM dimming technology, PHM dimming technology improves the uneven brightness of low-gray-scale LED significantly. As shown in Fig.6, when PHM is used, the number of LEDs displayed abnormally in the 48-gray-scale unit area of the G screen is reduced by about 80 %.

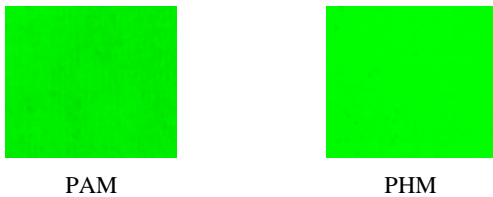

Figure 6. Comparison of PHM and PAM effects

Compared with PWM dimming technology, the flicker phenomenon of PHM dimming technology is slightly improved. As shown in Figure 7, the Flicker value of the white picture changes with the gray scale. In low gray scale, the Flicker value of PHM is similar to that of PWM. At high gray level, the Flicker value of PHM is lower than that of PWM, and the Flicker of PHM is obviously improved.

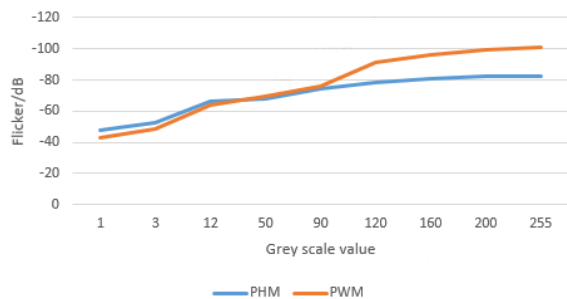

Figure 7. Flicker and gray-scale relationship diagram

4. Conclusion

This paper illustrates PHM dimming technology based on Micro LED display, and provides a mature and reliable Double Data PHM drive system for the Micro LED display. Compared with PAM dimming technology and PWM dimming technology, the width and amplitude of the driving pulse output by the system are adjustable, and the control of the brightness of Micro LED is more flexible. Therefore, the Micro LED drive pulse can be modulated to improve the spot defects and flicker phenomenon and improve the display performance without the sacrifice of gray-scale brightness requirements.

5. Reference

1. Yingteng Z ,Ji X ,Lei L , et al.5.1: A Novel PAM - PWM Hybrid Driving Method for Micro - LED Displays[J].SID Symposium Digest of Technical Papers,2022,53(S1):66-68.
2. Liu Y ,Que S ,Song Z , et al.38.2: An Accurate and Stable PWM Pixel Circuit Based on LTPO TFTs for AM - Micro - LED Display[J].SID Symposium Digest of Technical Papers,2023,54(S1):242-245.
3. Shao Z ,Fu J ,Liao C , et al.P - 4: Δ VTH and VSS IR rise Compensable PAM and PWM Combined Oxide TFTs Mini - LED Pixel Circuit Working at Low Voltage[J].SID Symposium Digest of Technical Papers,2023,54(1):1790-1793.
4. Liu C ,Zhou H Z ,Zhou L , et al.An analog PWM pixel circuit with shaping function for low grayscale display of Micro-LEDs[J].Engineering Research Express,2024,6(1):
5. Limin W ,Anyu L ,Yinfeng Z , et al.27.3: A Novel Hybrid Driving Method for Mini/Micro LED Display[J].SID Symposium Digest of Technical Papers,2022,53(S1):314-317.
6. Julian R ,Chihao X .P - 41: A Combined PAM / PWM Driving Scheme for High Uniformity of Micro - LED Displays[J].SID Symposium Digest of Technical Papers,2022,53(1):1204-1207.
7. Chu C ,Wu F ,Sun S .31.2: High PPI Micro - LED Display Based on PWM Technology[J].SID Symposium Digest of Technical Papers,2018,49337-338.
8. Lee J ,Su S ,Kuo Y , et al.24 - 3: Invited Paper: PAM and PWM Driving Comparison for Micro LED Display[J].SID Symposium Digest of Technical Papers,2023,54(1):321-324.